

# DTH -xx Assembly Schematic

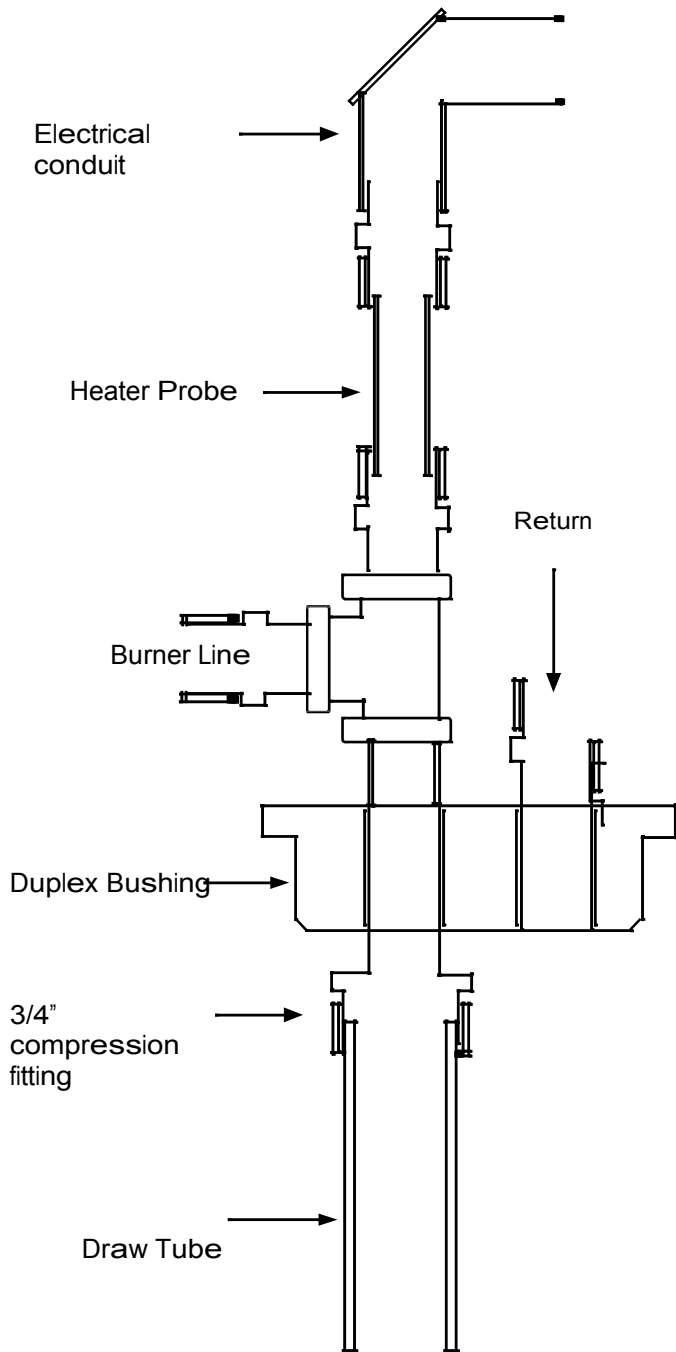

## Assembly Instructions:

The heater probe is a complete unit and can be installed with either a simple 1/2" bushing mounted on the tank top or as part of the draw tube assembly.

To install with the draw tube assembly refer to the schematic at left.

### Step 1 Assembly:

Attach the 3/4" compression fitting to the 3/4" draw tube. Make a good tight connection to prevent the burner from pulling air around the tube and fitting. Now screw the draw tube assembly into the bottom of the duplex fitting in the port mark "S".

#### NOTE:

If assembling the unit on-site then installing the duplex fitting into the tank top at this time will provide a solid mounting point and eliminates the need to hold it in a vise for the rest of the assembly.

Install the 1/2" pipe nipple on the top side of the duplex bushing in the port marked 'S'. Screw the Tee fitting onto the nipple.

Next, slide the heater assembly through the Tee fitting and secure with the 1/2" compression fitting already installed on the heater probe.

Attach the burner line to the 90 degree port of the Tee and either install the return or install a 1/2" plug as needed into the port marked 'R'.

#### NOTE:

Use a suitable pipe sealing compound or Teflon tape (if code allows) on all pipe fittings. Lack of a sealant could allow the burner to pull air into the system.

### Step 2 Wiring:

The heater is supplied with approximately 25 feet of wire. Connect the two wires from the heater to either of the two leads of the supplied wire, color is not important. Connect the other end of the wire to the power supply leads. Again, color is not important. Use the supplied wire nuts to make a secure connection and use flexible conduit or other suitable means to keep the connections dry.

#### Disclaimer:

Rollie Technical Systems warrants its products for 1 full year from the date of purchase. Warranty covers defects in material or workmanship only. Damage due to improper use or installation will not be covered.

Rollie Technical Systems, Inc. shall not be held liable for damages resulting from the use, misuse or mis-application of this product. It is intended for use as a fuel oil warmer only. Using this device in any other application without the written consent of Rollie Technical Systems will void all warranties and remedies. In no case, either approved or un-approved by us, Rollie Technical Systems will be held harmless for any and all damages caused by the use of this product. It is the sole responsibility of the purchaser to ensure that the product will work as intended in any and all applications.